

E-Compact

Less energy. More power.



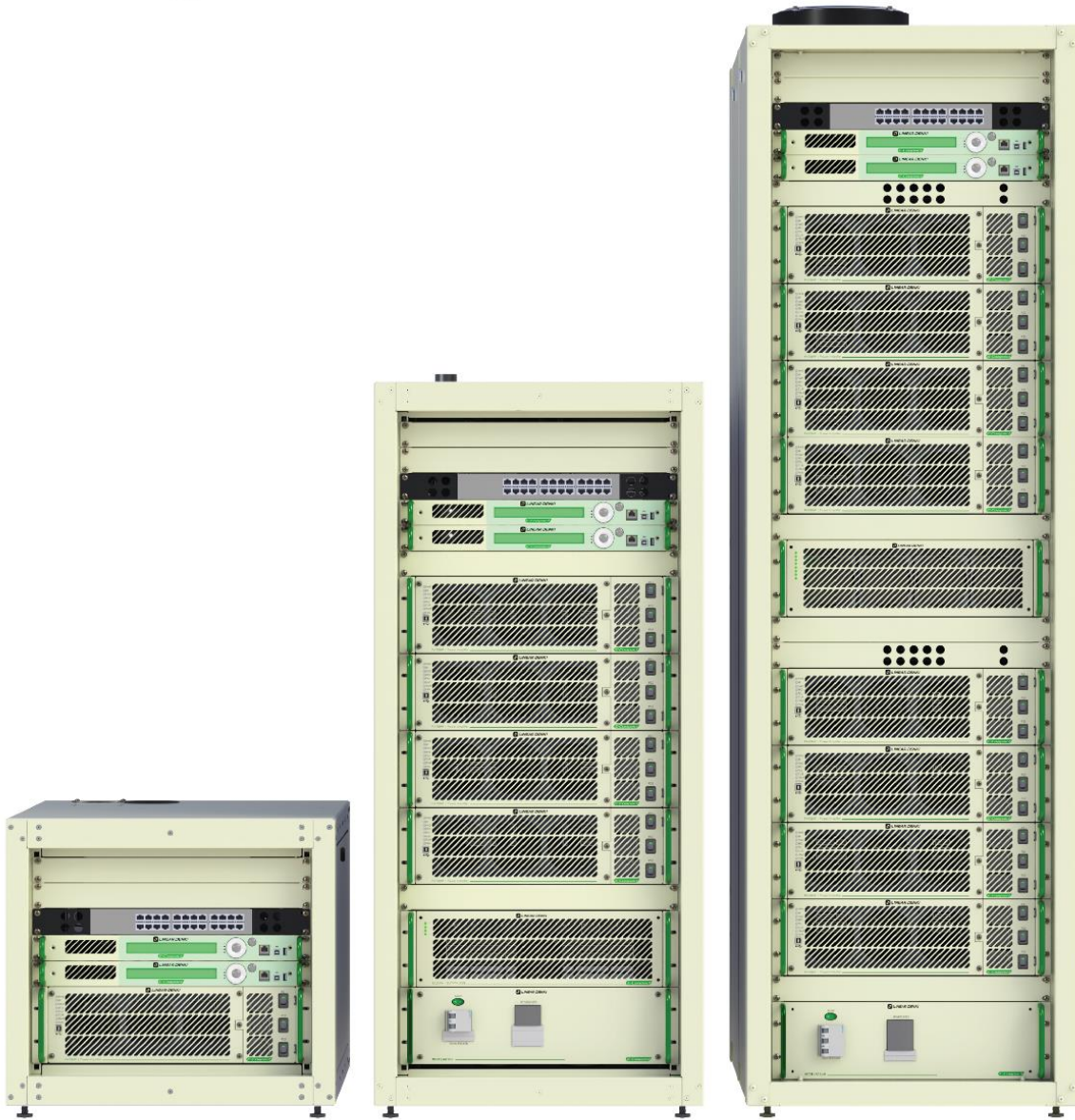

HP-BB Series - EX8001

High Efficiency UHF Broadband Transmitters

ISDB-T TV Digital: 680 to 8.400 Watts RMS



English

-  **ISDB-T**
Digital TV Standard
-  **High Efficiency**
-  **Redundant Power Supply**
-  **Smart Fan Control**
-  **Automatic Linearization**
-  **Embedded WEB Server**
-  **Remote Access**
-  **SFN**
-  **BTS Decomp**
-  **Remux**
-  **[****]**
Conditional Access
-  **Surge Protector**

HP-BB Series

E-Compact Family of High Power Broadband UHF Digital TV Transmitters features fully solid-state drivers, air-cooled and is structured on standard 19" cabinets.

Its compact design combines high power density per amplifier module and efficient energy consumption, embedded with Real Time A-DPD pre-correction technology that allows to recover MER values in an imperceptible way if there are changes in the equipment output power.

It features the option of Dual Exciter drivers, providing automatic redundancy to the equipment without the need for management by a separate control module.

Based upon Doherty topology Broadband Power Drawer delivers High performance with efficiency up to 41%, with three power supplies as standard thus assuring high reliability against power failures.

Highlights

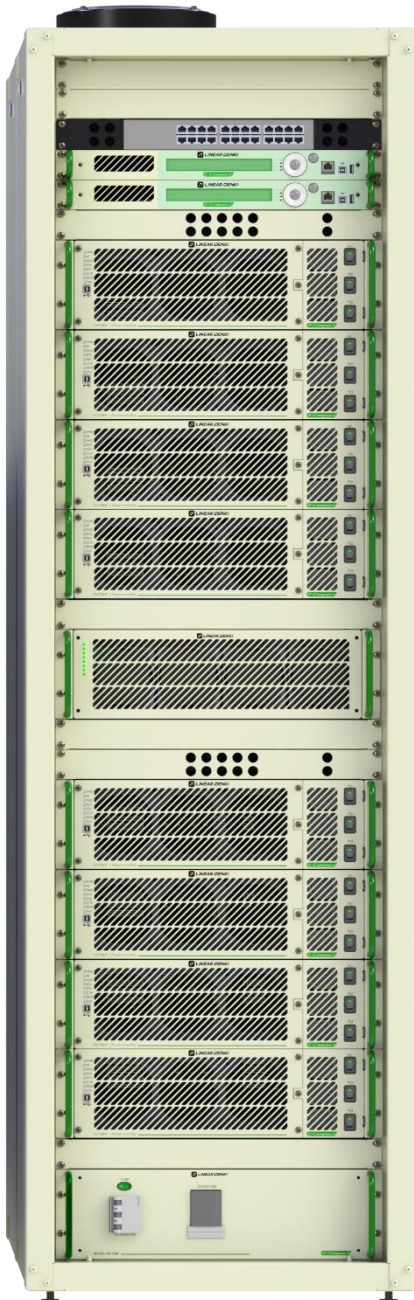

- ISDB-T EX8001-V4 Exciter.
- Full Equipment control, including Power Drawers, performed by the Exciter Driver, dispensing the need for external control units.
- Broadband Power Drawers with high efficiency Doherty topology, operating with up to 900 W RMS @ ISDB-T.
- Real Time A-DPD function automatic non-linear pre-correction and linear pre-correction.
- Built-in parameterizable BTS decompressor, compatible with other brands.
- Embedded remux, allows the signal adjustment according to the need for transmission.
- Onboard satellite receiver, with Free to Air, IRDETO⁵, CONAX⁵, BISS, VERIMATRIX⁵ and NAGRAVISION⁵ license options.
- Automatic fan speed control, resulting in low noise levels, energy savings and longer device life.
- High reliability against failures. Three power supplies for each Power Drawer. Balanced distribution of electrical network in a three-phase system.
- "Easy Maintenance" concept offering, among others, Plug-In connection for Power Supplies and Power Drawers.
- Insulated RF² combiners enabling Hot Swap¹.
- MCCB (Molded Case Circuit Breaker)², AC distribution module with SPD protection circuit – Surge Protection Devices (optional).

Available resources

<p>MCCB (Molded Case Circuit Breaker)² AC distribution module with load capacity from 8kW to 30kW consisting of circuit breakers, In-Rush limiting system, phase loss protection, mains overvoltage protection, under voltage protection (<180VAC), auxiliary +50VDC, +15VDC and +8VDC power supplies and safety interlock input for equipment power cut off.</p>	AVAILABLE
<p>Easy Maintenance concept Power Supplies and Power Drawers with plug-in connection, does not require the use of cables and wiring, allowing quick and safe replacement.</p>	AVAILABLE
<p>Embedded WEB Server Remote access³ of the settings and management of the transmitter through the Ethernet⁴ port is possible, using a PC or Smartphone browser, without the need to install drivers or applications.</p>	AVAILABLE
<p>Real Time A-DPD Linear and Nonlinear Pre-Correction Imperceptible Automatic pre-correction applied due to changes in transmitter output power to recover MER values and intermodulation.</p>	AVAILABLE
<p>BTS Decompression Parameterizable BTS decompressor, embedded in the Transmitter, eliminating the use of auxiliary devices in the system, thus permitting interoperability with other brands.</p>	AVAILABLE
<p>Embedded Remux PID filtering, insertion of PSI/SI static tables, Virtual Channel configuration and TMCC parameterization.</p>	AVAILABLE
<p>Exciters Inputs / Outputs <i>Inputs:</i> BTS/TS over IP, 2x ASI/310M, 1PPS, 10MHz e ANTENA GPS. <i>Outputs:</i> 2x ASI/310M, 1PPS, 10MHz, 2x USB 2.0 Type B, USB 2.0 Type A and Ethernet⁴ RJ45. <i>The BTS/TS over IP input can be converted to ASI and made available on the ASI/310M outputs without interfering with the modulating signal.</i></p>	AVAILABLE
<p>Passive Elements Critical Mask Filter (50dB), Low Pass Filter, RF probe before mask filter², RF probe after mask filter.</p>	AVAILABLE
<p>Insulated RF² combiners enabling Hot Swap¹.</p>	AVAILABLE
<p>1200W Power Supply Three 1200 Watt power supplies per power drawer. Operation with power redundancy. Power Supplies with plug-in type connection ("Easy Maintenance" concept), eliminates the use of cables and wiring, for quick and safe replacement.</p>	AVAILABLE
<p>Digital manuals in English.</p>	AVAILABLE
<p>Dual Exciter Backup driver, which allows automatic redundancy, without the need for management by a separate control module.</p>	OPTIONAL
<p>SPD (Surge Protection Devices)² Extra protection against power grid overvoltage surges.</p>	OPTIONAL
<p>Ethernet⁴ Switch standard cabinet 19" Standard with the Double Excitement option.</p>	OPTIONAL
<p>Instrumental through Software Pre-correction tool, MER reading, constellation and spectral density (GUI8001).</p>	OPTIONAL
<p>GPS time base High precision time base sync via GPS. High performance running on SFN (Single Frequency Network). Features an external GPS antenna and surge protector.</p>	OPTIONAL
<p>UHF Tuner (Terrestrial Reception) ISDB-T UHF receiver and demodulator for terrestrial signal retransmission. It comes with a 5 or 7 pole mechanical tuning filter, depending on the conditions of the adjacent channels.</p>	OPTIONAL
<p>SAT Tuner (Satellite Reception) L-Band DVB-S/S2 receiver compatible with C-band and Ku-band LNBs. Electric surge protector included.</p>	OPTIONAL
<p>CAS Tuner (Satellite Reception with Conditional Access) L-Band DVB-S/S2 receiver compatible with C-band and Ku-band LNB. It performs the decryption of up to 04 services simultaneously and visualization of up to 08 services on the display. Electric surge protector included.</p>	OPTIONAL
<p>Decryption Licenses for CAS Tuner: IRDETO⁵, CONAX⁵, BISS-1, NAGRAVISION⁵ and VERIMATRIX⁵ Decryption licenses can be purchased individually or together, for new transmitters or for transmitters that are already in field operation. In some cases it is possible to enable licenses remotely.</p>	OPTIONAL
<p>Remote telemetry over GPRS Transmitter remote monitoring using the GPRS cell phone network.</p>	OPTIONAL
<p>Manuals printed in English.</p>	OPTIONAL

General features

- Mounting in standard 19" Rack cabinet;
- Fully solid state;
- 900 Watt RMS Doherty Power Drawers with LDMOS Transistors;
- Air cooled;
- Automatic restart in case of power failure;
- Operates on SFN (Single Frequency Network) and MFN (Multiple Frequency Network);
- All equipment controlled and managed by firmware;
- Access to settings and management of parameters via display interface on the front panel of the Exciter or remote³ via Ethernet⁴ (WEB server or SNMP);
- Alarm signaling LEDs present on the front panel of the Exciter and Power Drawer;
- Access the list of current or occurred alarms via display interface on the front panel of the Exciter or remotely³ via WEB interface;
- VSWR and Overpower protection via hardware and software, with automatic power reduction;
- Software protection against module temperature increase, with alarm signaling and power reduction;
- Automatic fan rotation speed control;
- Automatic quiescent bias current compensation of power transistors as a function of temperature;
- Transistor AGING compensation adjustment via Exciter front panel display;
- USB communication drivers;
- Automatic and programmable input switching in hold on and hold off modes;
- Power supply with PFC (Power Factor Correction) and soft starter with In-Rush limitation.
- RF interconnections between equipment parts with rigid line.

Models and their specific characteristics (EX8001 - ISDB-T)

	EC701HP-BB* Available with EX9001	EC702HP-BB* Available with EX9001	EC703HP-BB	EC704HP-BB	EC706HP-BB	EC708HP-BB	EC712HP-BB
Output power after filter	680 W	1.400 W	2.100 W	2.800 W	4.200 W	5.600 W	8.400 W
Output power before filter	850 W	1.720 W	2.560 W	3.420 W	5.120 W	6.830 W	10.000 W
AC consumption ⁶	2.340 W	4.620 W	6.900 W	9.180 W	13.740 W	18.300 W	27.420 W
Thermal dissipation ⁶	5.664 BTU/h	10.987 BTU/h	16.378 BTU/h	21.769 BTU/h	32.552 BTU/h	43.334 BTU/h	64.899 BTU/h
Efficiency after filter ⁶	29,1 %	30,3 %	30,4 %	30,5 %	30,6 %	30,6 %	30,6 %
Efficiency before filter ⁶	36,3 %	37,2 %	37,1 %	37,2 %	37,3 %	37,3 %	36,5 %
Power Drawers	1	2	3	4	6	8	12
Number of Cabinets	1						2
Rack Units (19")	8 RU	25 RU			40 RU		
Width	570 mm 22 7/16 in						1.140 mm 44 7/8 in
Length	900 mm 35 7/16 in	1.100 mm 43 5/16 in					
Weight	70 Kg 154,32 lb	170 Kg 374,79 lb	210 Kg 462,97 lb	250 Kg 551,16 lb	350 Kg 771,62 lb	420 Kg 925,94 lb	700 Kg 1.543,24 lb

*Equipment also available with EX9001 exciter (consult specific catalogue).

Transmission Spectrum Mask (Intermodulation) ⁷

	Critical Mask	Subcritical Mask	Non-critical Mask
±3,15 MHz @ BW = 6 MHz	≥50 dB	≥43 dB	≥36 dB
±4,50 MHz @ BW = 6 MHz	≥67 dB	≥60 dB	≥53 dB
±9,00 MHz @ BW = 6 MHz	≥97 dB	≥90 dB	≥83 dB
±15,00 MHz @ BW = 6 MHz	≥97 dB	≥90 dB	≥83 dB

Transmission spectrum mask according to ABNT NBR 15601:2007

Technical Characteristics

RF	
Standard	ISDB-T
Operation frequency	470 MHz to 608 MHz (Chanel 14 to Chanel 36)
	608 MHz to 698 MHz (Chanel 37 to Chanel 51)
Bandwidth	6 MHz / 8 MHz
Minimum operating power	10 % of rated power
Pré-correction	A-DPD – Non linear
	Pré-correction Linear
Typical MER	35 dB minimum
	38 dB typical (depends on channel, power and transmitter efficiency)
Out-of-channel spurs and harmonic distortions	Better than -60 dBc
Transmission Mask (Intermodulation)	Critical mask
Power stability	±2 %
RF output impedance	50 Ω
Output Connections *	EIA 1-5/8" @EC701HP-BB, EC702HP-BB, EC703HP-BB and EC704HP-BB
	EIA 3-1/8" @EC706HP-BB, E708HP-BB and EC712HP-BB

ASI Inputs / Outputs	
Quantity	02 inputs, 02 Outputs
Standard	DVB-ASI 188 /204 BYTES
Connectors	BNC Female
Impedance	75 Ω

Input TSoIP	
Standard	IEEE802.3u 10 Base-T /100Base TX
Connector	RJ45
Encapsulation	UDP/RTP
IP assignment	Static
Multicast	IGMP v2

GPS antenna input (optional)	
Connectors	SMA Female
Impedance	50 Ω
Accessories	External antenna, cable and surge protector

UHF tuner input (optional)	
Reception band	UHF
Standard	ISDB-T
Connectors	SMA Female (Exciter) N Female (input UHF filter)
Impedance	50 Ω

Satellite tuner input (optional)	
Reception band	L band
Polarization	Vertical / Horizontal
LNB voltage	+13 V, +18 V
Standard	DVB-S / DVB-S2
Connectors	SMA Female (Exciter) F Female (connection w/ LNB)
Impedance	75 Ω
Accessories	surge protector

CAS tuner input (optional)	
Reception band	L band
Polarization	Vertical / Horizontal
LNB voltage	+13 V, +18 V
Standard	DVB-S / DVB-S2
Connectors	SMA Female (Exciter) F Female (connection w/ LNB)
Impedance	75 Ω
Optional decryption licenses*	IRDETO CONAX NAGRAVISION VERIMATRIX BISS-1
Accessories	surge protector

10MHz external references - Input / output	
Quantity	01 input, 01 output
Connector	BNC Female
Impedance	50 Ω
Input level	0 a +10dBm
Output Level	+10 dBm

1PPS external references - Input / output	
Quantity	01 input, 01 output
Connector	BNC Female
Impedance	1 kΩ
Input level	3V3 LVTTTL
Output Level	3V3 LVTTTL

Linearization inputs. After Filter / Before Filter.	
After Filter Input	Linear pre-correction
Before Filter Input	Nonlinear pre-correction
Connector	SMA Female
Impedance	50 Ω
Input level	-5 to +5 dBm

Local oscillator	
Oscillator	Synthesized by PLL
Frequency stability	±1 Hz (with Internal GPS) ±35 Hz (without Internal GPS)
Phase noise	≤-95 dBc/Hz @ 1 kHz
ISDB-T Modulation	
Mode OFDM	Mode 1: 2K (2048/3,96 KHz) Mode 2: 4K (4096/1,98 KHz) Mode 3: 8K (8192/0,99 KHz)
Guard interval	1/4, 1/8, 1/16, 1/32
Partial reception	Single segment for mobile devices (1-Sec)
Hierarchical Transmission	Support for 3 layers (A, B and C)
Segments	1 to 13
Modulation	QPSK, DQPSK, 16QAM, 64QAM
FEC	1/2, 2/3, 3/4, 5/6, 7/8
Time Interleaving	0, 1, 2, 4
Electrical Characteristics	
Mains (Factory Configured)	Single-phase 220VAC (M220) ⁹ Biphasic 220 VAC (B220) ⁹ Three-phase 220 VAC (T220) Three-phase 380 VAC (T380)
AC input voltage	180–254 VAC
AC frequency	43–63 Hz
Quantity of sources per Power Drawer	03 PSU
PFC	0,95 (typical), 0,9 (minimum)

Interfaces	
Equipment local control interface	Display LCD 2x40 An keyboard
Signaling leds	Alarm LEDs on the exciter and power drawers
USB	USB 2.0 type B (rear panel) USB 2.0 type A (front panel) USB 2.0 type B (front panel)
Remote access	Connector RJ45 (front panel) Format IEEE802,3u 10 Base-T /100Base TX
Communication interfaces	Ethernet ⁴ WEB server SNMP Interface GUI8001
Environment Features	
Operating altitude	Up to 2.500 meters (8.200 ft) ¹⁰ above sea level
Environment temperature range	0°C (32°F) to + 45°C (113°F) +25°C (77°F) recommended
Environment humidity range	0 to 95 % non-condensing
Power amplifier cooling	Forced ambient air, front-to-rear flow through high-volume integral fans

Combined Assembly

EC708HP-BB (EX8001) COMBINED: ISDB-T TV Digital 10kW RMS

Transmitter system with combined output power after filter 5kW RMS in single mode or 10kW RMS in combined mode. It has an integrated redundant control system that enables individual or integrated operation of the transmitters even in case of main control failure.

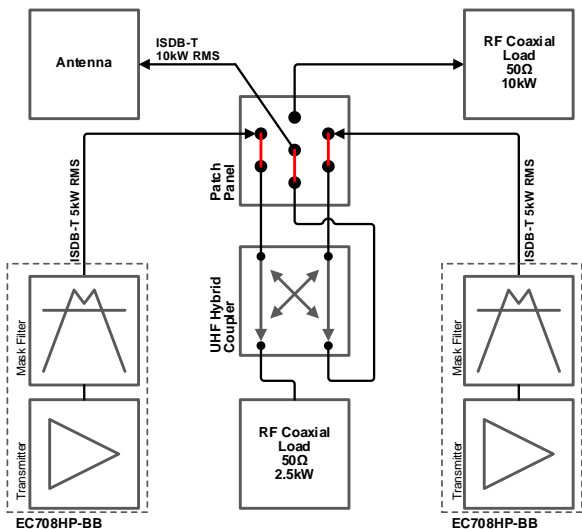

Combined System Characteristics

Two E-Compact Transmitters model EC708HP-BB with critical mask filter combined with Independent operation;

7-way EIA 3-1/8" Coaxial Patch Panel for switching between antenna, coaxial load, Transmitter A, Transmitter B or Transmitter A + Transmitter B with rigid line RF interconnections;

50Ω coaxial load of 10kW RMS coupled to the Patch Panel output for use in eventual system maintenance;

Hybrid Combiner and 2.5 kW unbalance load present in the combination system.

Control and protection module of the combined system present in both transmitters working as Main and Redundant;

Control and adjustment of the total system or individual output power level of each transmitter executed through the front panel of each transmitter or remotely via the WEB interface.

Manual switching operation in Patch Panel that allows the following settings:

Transmitter A + B connected to antenna.

Transmitter A + B connected to coaxial load.

Transmitter A connected to Antenna / Transmitter B connected to coaxial load.

Transmitter B connected to Antenna / Transmitter A connected to coaxial load.

System Performance

Output power after filter
(Combined) 10000 W

AC consumption ⁶ 39600 W

Thermal dissipation ⁶ 101060 BTU/h

Efficiency after filter ⁶ ≥25,2 %

Typical MER
(Combined) ≥38 dB

System Dimensions

Height 2160 mm
85 3/64 in

Width 2000 mm
78 3/4 in

Length 1925 mm
75 25/32 in

Notes:

¹ The Power Drawers can be removed or inserted with the Transmitter in operation, however the Power Drawer to be removed or inserted must have the AC switches on its front panel in the OFF position.

² Except EC701HP-BB model.

³ Consult factory to use transmitter Web Interface access on the same network with multicast stream.

⁴ Ethernet is a trademark of Xerox Corporation.

⁵ Module with PCMCIA CAM slot (Irdeto, Conax, Nagravision and Verimatrix systems), SMARTCARD and CAM not included.

⁶ Considering optimized channel and environmental conditions. It may vary according to channel frequency and operating conditions.

⁷ The transmission mask depends on the type of filter used.

⁸ Consult factory for other types of output connections.

⁹ AC Power On Request for EC706HP-BB, EC708HP-BB and EC712HP-BB models.

¹⁰ Rated power up to 2.500 meters (8.200 ft). Above 2500 meters (8.200 ft), consult factory.

KOKUSAI DENKI Electric Linear S/A

Avenida Frederico de Paula Cunha, 1001 – Maristela
Santa Rita do Sapucaí – MG – Brasil – CEP: 37536-162
Telephone: +55(35) 3473-3473
www.lineardenki.com.br
www.kokusai-denki.com.br

©Copyright 2025 KOKUSAI DENKI Electric Linear S/A. All rights reserved.

The Linear Denki brand and the products mentioned in this document are registered trademarks and the exclusive property of KOKUSAI DENKI Electric Linear S/A. Product specifications are subject to change without notice. The images shown are for illustrative purposes only.

REV07 – JANUARY/2025